

CONTENTS

[Disassembly](#)

[Soldering Notes](#)

[Messiah 2 Installation](#)

REASSEMBLY

[Using the Messiah 2](#)

[NTSC/PAL Colour Fix](#)

[Troubleshooting](#)

[Disclaimer](#)

Amended to:

- v1.1 Provide advice on the use of Kynar wire in relation to soldering to the VIAs (B – I)
- v1.2 Add EJECT wire instead of RESET wire
- v1.2 Clarification on the colour fix (it's the TV that matters)
- v1.2 Specific advice on checking for trapped wires
- v1.3 Actel ProAsic chip included
- v1.3 Alternate CD/DVD Controller points added
- v1.3 Minor bug referenced on booting DVD backup games

DISASSEMBLY

Prior to disassembly, test the PS2 for both CD and DVD games. This should then be the first test to perform when the PS2 is re-assembled.

You will need the following tools to accomplish the disassembly task

1. A Philips screwdriver for [Disassembly/Reassembly](#)
2. An optional pair of TWEEZERS (a TWEEZER) to manipulate the flat cables
3. Double-sided tape to hold detached objects and the Messiah 2 in a stable position

Detailed disassembly instructions are provided in a separate document (split out for size reasons when posting on the forums).

Please note that disassembling the PS2 which requires removal of the warranty sticker renders void the manufacturer's warranty and by doing so you accept all associated risk.

When you have disassembled your PS2, you are ready to commence installation of the modchip.

SOLDERING NOTES

The recommended equipment needed for the soldering job is:

- a) 15-18 watt soldering iron for the solder work (not higher than 18 watt or damage could result)
- b) 25-35 watt soldering iron (450°C) for stripping enamelled copper wire** (if you use that wire)
- c) 0.10 mm solder tip (this is very small)
- d) 36 swg wire (=32 awg) ** for all except 3.45v and GROUND
- e) 23 swg = 22 awg insulated stranded wire for 3.45v and GROUND
- f) Liquid Flux for assisting in the cleaning of target points
- g) Solder paste (a mixture of flux and solder) to assist soldering to lacquered points
- h) De-soldering braid
- i) A safety razor blade & Blue Tack (plastic dough) to hold the razor blade in place
- j) Double sided tape to fix the mod chip into final position

** "Self-Stripping" (a misnomer), enamelled copper wire is recommended rather than sheathed as it requires less space and is easier to feed through to the other side of the motherboard.

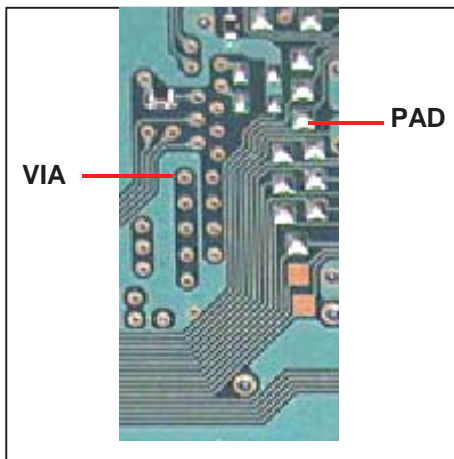

With reference to the picture on the left, it is straightforward to solder a wire to a **PAD**.

However soldering a wire to a **VIA** must be performed with great care since damage to a VIA can ruin the motherboard. If you solder to a VIA, you would strip and tin your wire, dip it in solder paste, spray the VIA with flux spray and touch solder the wire end for half a second to just above the end. This is sufficient for the solder paste to take the lacquer away from the VIA and bond the tinned end to the VIA. If you linger too long with the iron, the VIA will disappear into the motherboard layers and it's all over.

Kynar wire is not considered suitable for soldering to vias.

Generally, this is the soldering technique where the **small processor pins** are involved:

- Strip the solder end of the enamelled copper wire using the hot 25W iron.
- Dip the stripped end into the solder paste
- Squirt a small amount of flux spray onto the BIOS pins to assist adhesion of the solder
- Solder to the pin using the razor blade technique described below.

The **razor blade technique** is to place a single safety blade between the pin on which you are working and a neighbour. This protects the neighbour from bridging and splatter. With your **0.1mm tip** and 15W or 18W iron, work towards the blade (so as to avoid contaminating the other neighbour).

For the **Ground pads** a low wattage iron is somewhat challenged. The tip must be clean so that it is able to reach full temperature; the Ground pad should be scraped back to bare copper which should then be freshly tinned, as with the end of the Ground wire and heat then applied to the end of the wire touching the tinned pad.

Wire layout is important. The wires should be laid flat along the motherboard and exposed soldered ends should be kept short. **Hot glue** should be used to hold the wires down so that they are not compressed when the metal cover is put back; if they are compressed, there is a danger that the soldered ends will bow and thus short circuit.

MESSIAH 2 INSTALLATION

There are 24 wires to solder and this is a **difficult, specialised job**. The Messiah 2 is small (the pictures below are at c. 8x magnification). Please note that on the v9 PS2, the **RESET** button cannot be used to disable the Messiah 2 since holding the button down for 4 seconds actually turns the PS2 off. Thus the **EJECT** button is now used and hence the **RST** point on the Messiah 2 chip is thus connected to the **EJECT** point on the PS2 motherboard.

There are two versions of the Messiah 2 chip in circulation as pictured below.

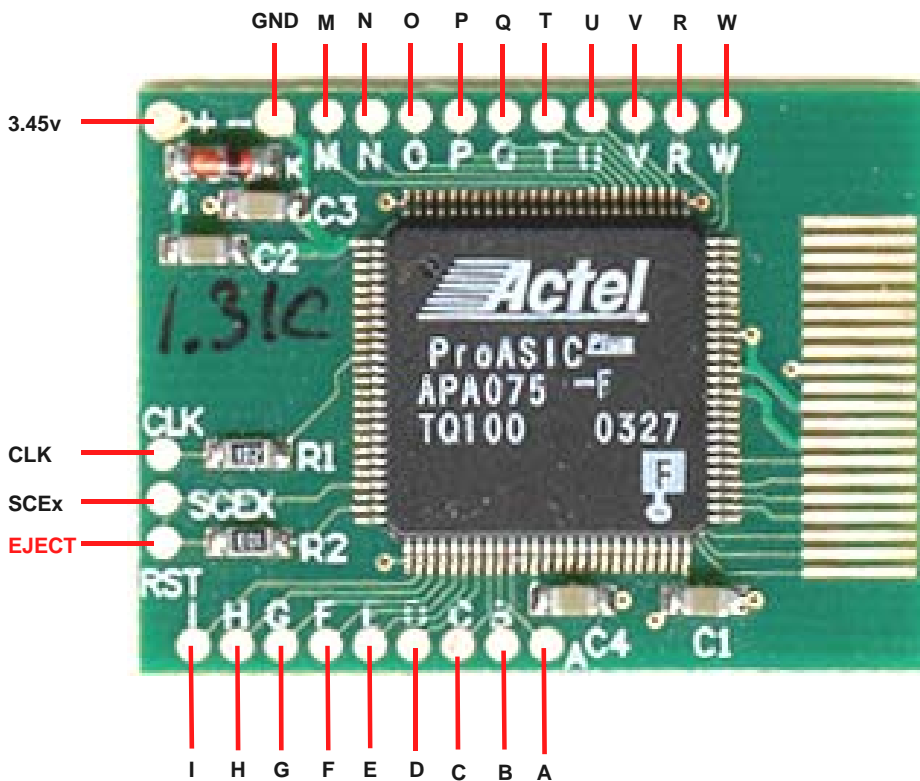
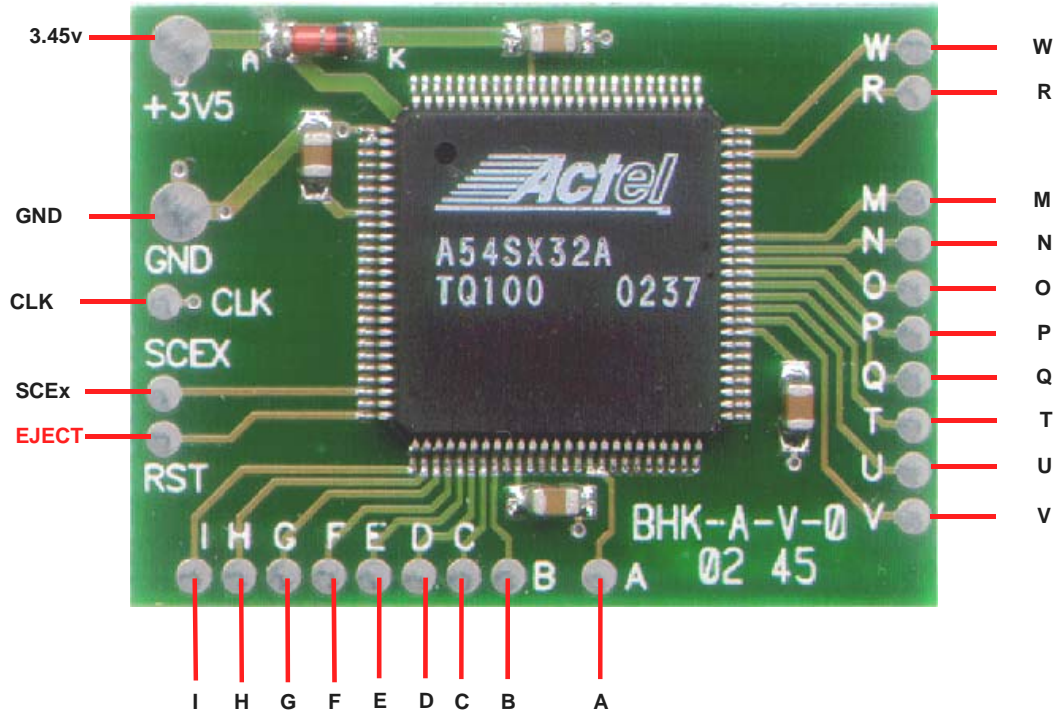

The **low resolution photographs** are for positional orientation (rather than magnification). The Messiah 2 mod is slim enough to be fixed onto the 'vacant' area on the PS2 motherboard.

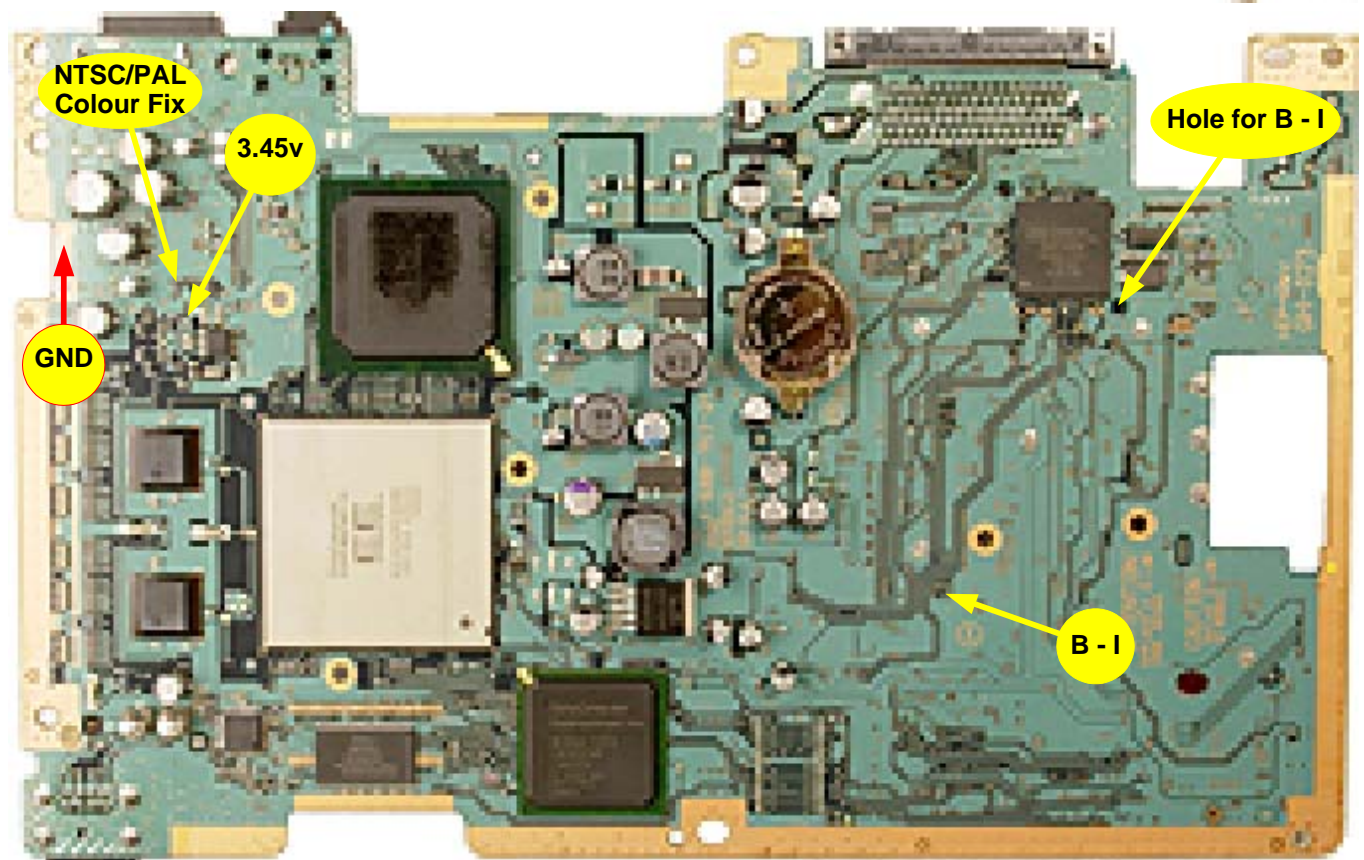
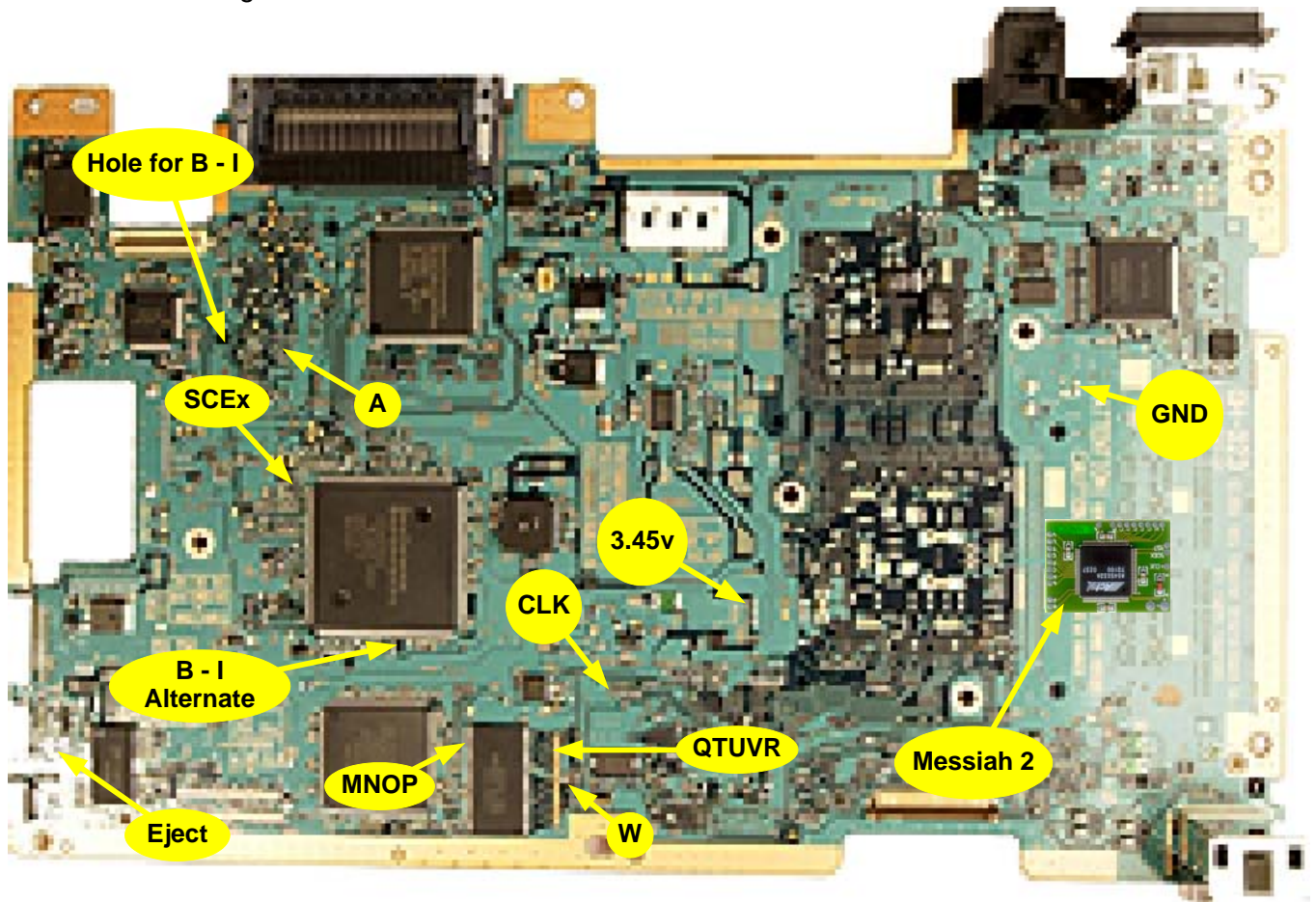

It is recommended that you solder to the PS2 motherboard first and then connect each wire to the appropriate point on the Messiah 2.

Power (3.45v), Ground (GND), RESET and SCEx

Install these points first. Note that **3.45v** & **GND** are 23 or 25 swg = 22 or 24 awg insulated stranded cable.

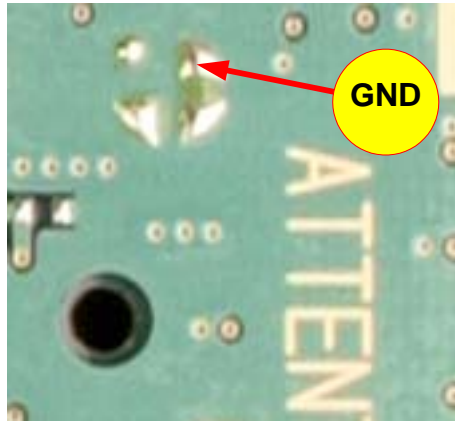
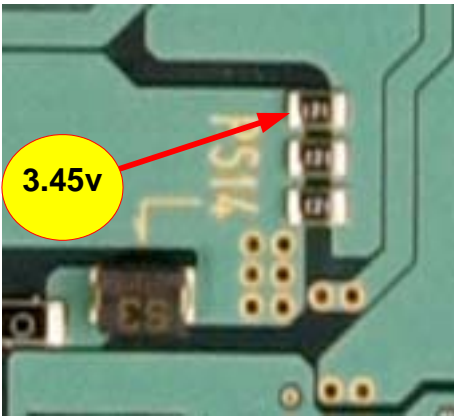

The GND copper pads are covered with lacquer that must be scraped off or the lacquer removed with flux spray as described in the [soldering](#) section.

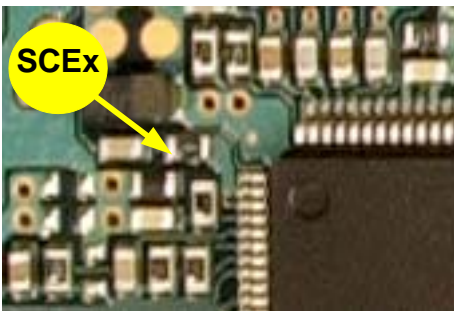

Care should be taken to ensure that the **SCEx** signal wire is properly soldered to its correct location on the resistor; the bond must be good (without damaging the resistor). This signal is used to boot PS1 backup games.

The **EJECT** point (see right) is very important (they all are). If it is not correctly wired to the modchip, Messiah 2 will be unable to discern when you've switched to PS1 or sleep mode.

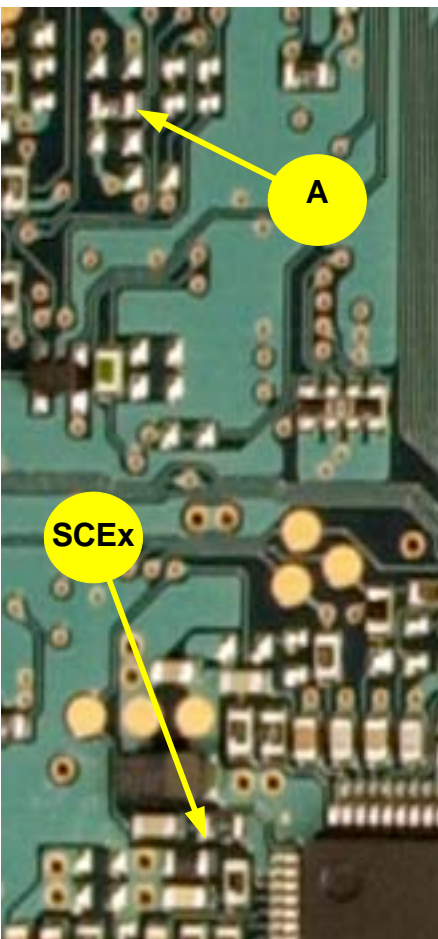
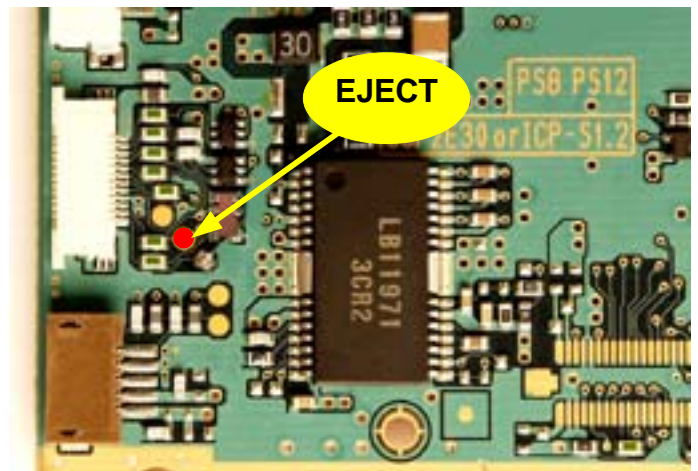

Now connect the **A** wire as per the photograph to the left. (**SCEx** is shown for positional reference).

(Unlike the v7/v8, the **B** & **C** wires are not soldered on the "topside" of the motherboard.)

Next come the **BIOS (MNOP QRTUVW)** and the **CLK** points. The BIOS pins are very close together; so you should take one safety razor blade (or Exacto blade) and some blue-tack (plastic dough) into which you would bed the blade. The blade would be placed between the pins (**MNOP**) to prevent solder from bridging to the adjacent pins. You would work the soldering iron towards the blade.

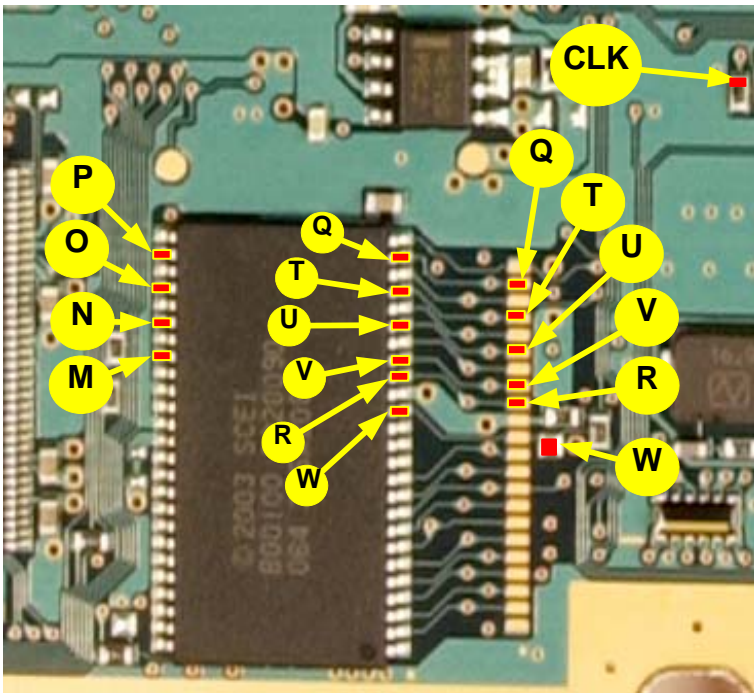

BIOS points **QRTUVW** should be soldered first (to the pads or to the legs according to your preference) followed by **MNOP** which should traverse the BIOS chip and be secured to the top of the chip with Epoxy glue (lower photograph).

Note that there is very little available solder on each BIOS pin and you should be skilled in soldering techniques to ensure a good bond.

The **CLK** point needs to be carefully wired back to the Messiah 2. **The wire should be laid along a ground plane – i.e. flat along the motherboard without traversing any surface mounted components.**

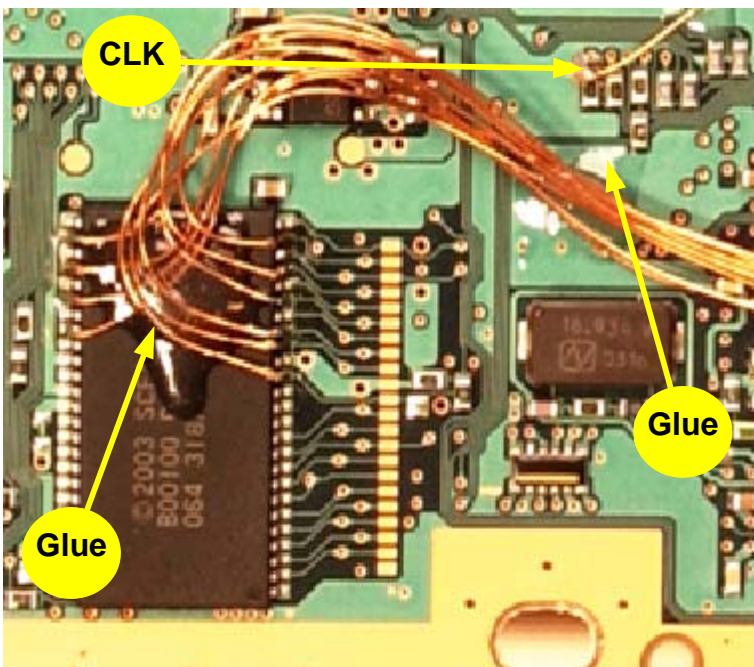

This completes wiring to the “top” side of the PS2 motherboard.

YOU NOW HAVE TWO CHOICES FOR SOLDERING WIRES BCDEFGHI. You can either solder to the VIAs on the other side of the PS2 (expert installers) or to the actual pins on the CD/DVD DSP using the Razor Blade Technique described in soldering techniques.

SOLDERING BCDEFGHI TO THE VIAs

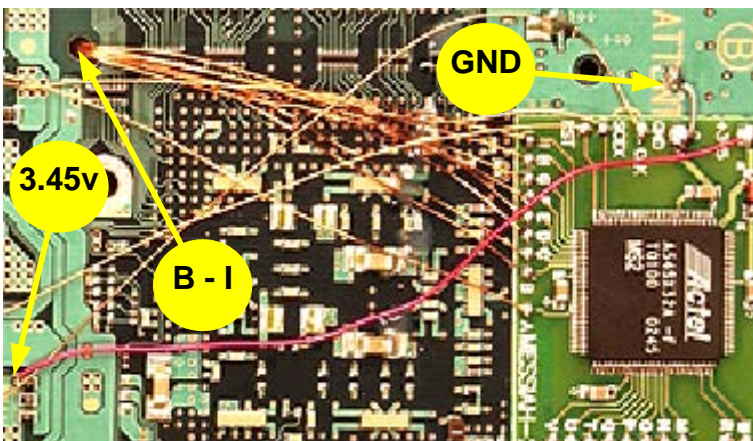

Note the position on the PS2 motherboard topside of the hole through which wires **BCDEFGHI** are to pass. (See picture to the left). Ensure you have enough wire length to run from the CD/DVD Controller vias on the underside, through the hole to the Messiah 2 chip (see photograph below). You are advised to solder to the vias first, and then pass the wires through the hole.

Kynar wire is **NOT** recommended for soldering to VIAs. Enamelled Copper Wire is easier to work and make stick.

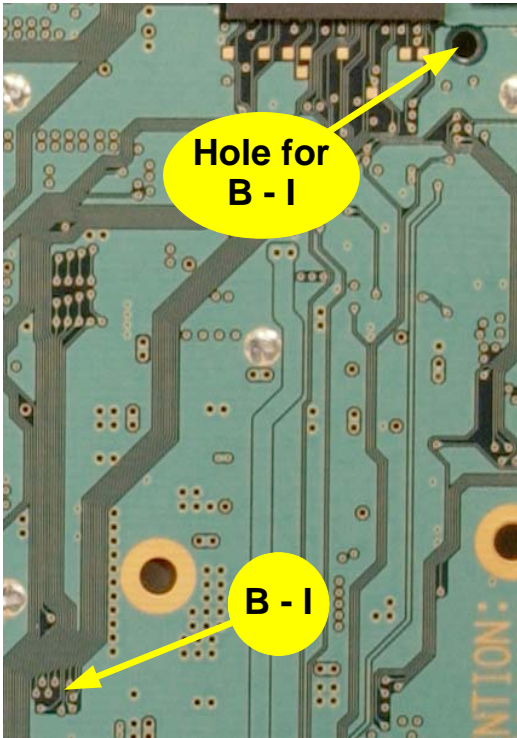

Turn the PS2 motherboard over. Locate the PS2 CD/DVD Controller vias (with reference to photograph on the right). Solder **BCDEFGHI** to the vias located in the picture below

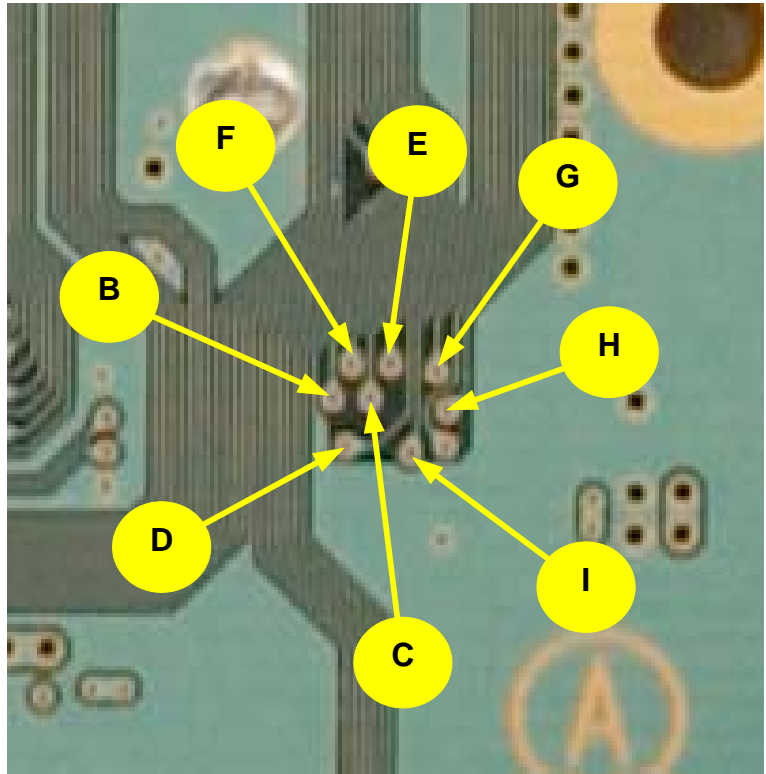

You could place a sticky identification label onto each wire to ensure correct connexion to the Messiah 2. Alternatively, connect each wire in turn to the Messiah 2; this will avoid cross-connected any wires.

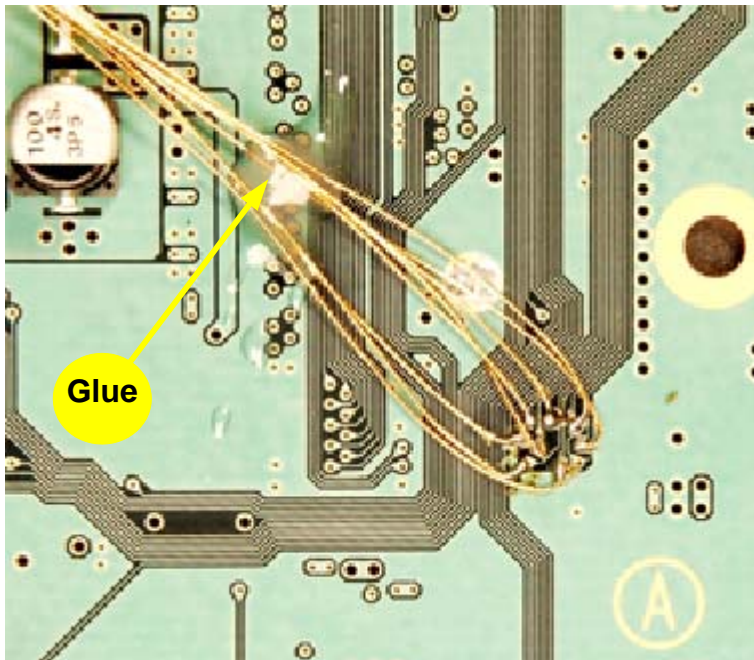

Note the glue applied to the finished job on **B-I** (see photograph to the left).

When this is done, **Messiah 2 wiring to the motherboard is complete** and the connexions can be made to the Messiah 2 with reference to the [Messiah 2 Schematic](#).

If you wish, and while you are on that side of the motherboard, you may also implement the **NTSC/PAL COLOUR FIX** as documented below.

SOLDERING BCDEFGHI TO THE CD/DVD DSP

Acknowledgement is made to George Villas (<http://www.grmods.com/villasg>) for posting the pictures shown here in PS2Newz and other forums.

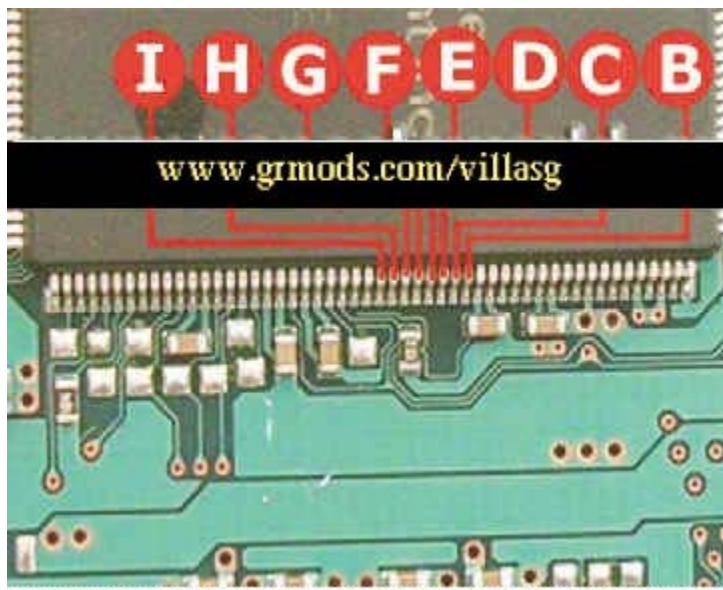

The Razor Blade Technique described in [soldering techniques](#) should be used to work with the closely spaced pins. If you bridge any of these pins (which in itself won't destroy the DSP), the Messiah 2 will not work.

If this method is used, there is no need to run any wires to the other side of the PS2 motherboard.

The result can be seen in the photograph below, also courtesy of George Villas.

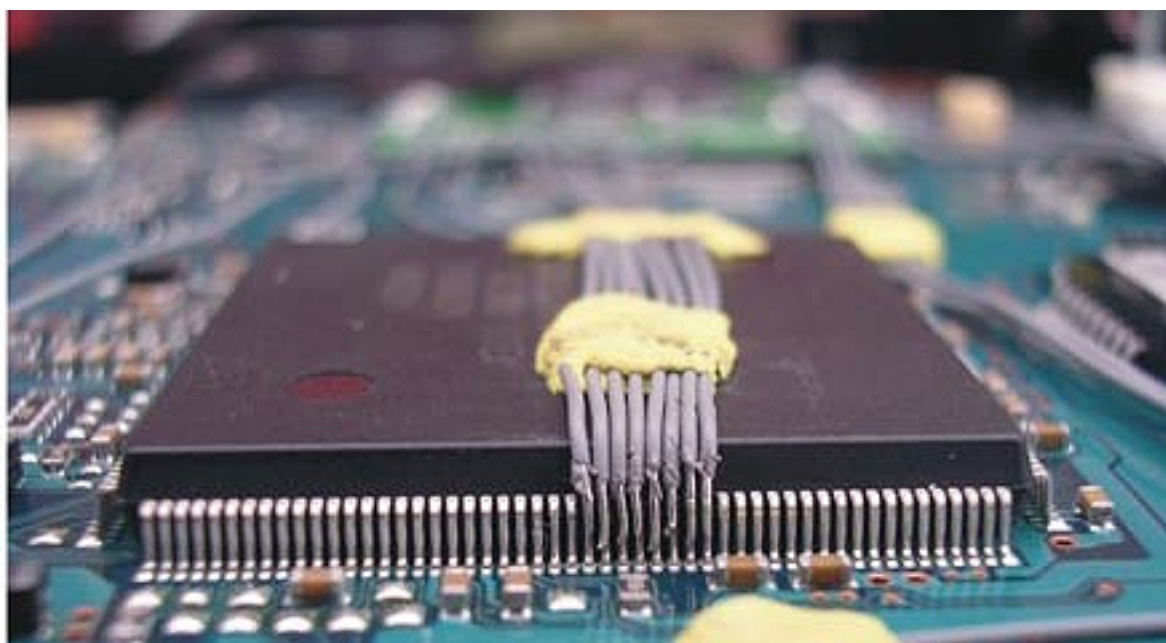

When this is done, **Messiah 2 wiring to the motherboard is complete** and the connexions can be made to the Messiah 2 with reference to the [Messiah 2 Schematic](#).

If you wish you may also implement the **NTSC/PAL COLOUR FIX** on the other side of the motherboard as documented below.

NTSC/PAL COLOUR FIX

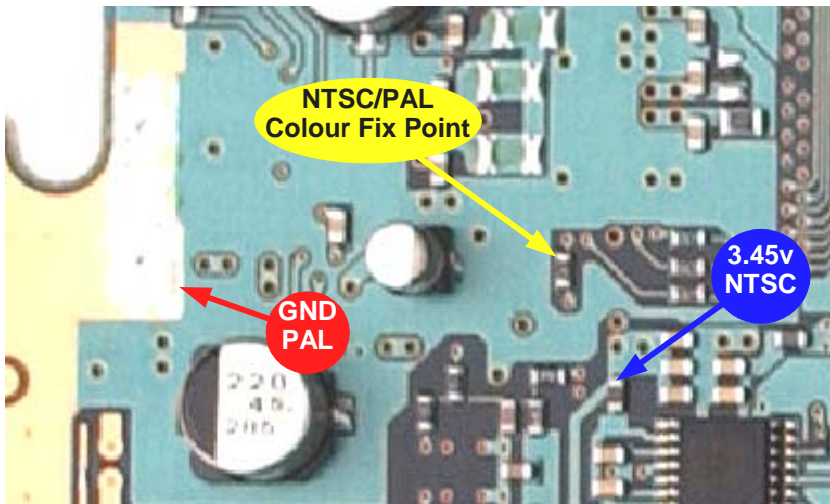

If you have an **NTSC** TV the *Colour Fix point* is taken to **3.45v**. It forces **NTSC** colour on all PS2 game output. All **PAL** games will then be put out in **NTSC** colour mode and all PS1 games will display proper **NTSC** colour. The frame rate for **PAL** games will remain at 50 Hz.

If you have a **PAL** TV the *Colour Fix point* is taken to **GND**. All **NTSC** games will then be put out in **PAL** colour mode. The frame rate for all **NTSC** games will remain at 60 Hz.

This fix has the advantage of ensuring that games from any region play in the selected colour mode provided that the TV will support the original frame rate.

There is a [detailed description](#) of the issues around this fix in the Troubleshooting section of this Install Guide.

REASSEMBLY

Reassembly is essentially the reverse of disassembly. These steps are:

1. Carefully place the PS2 motherboard onto the bottom casing ensuring that everything sits square. Take care that no damage occurs to the memory card/controller cable (which should have been taped down).
2. Reattach the memory card/controller flat cable to the PS2 motherboard and refasten its securing clip.
3. Seat the memory card/controller back into position and re-insert the two brass screws to fasten the PS2 to its lower casing. The locator pins for the memory card/controller go into the middle locating holes.
4. Reattach the disk drive cables to the PS2 motherboard.
5. Insert the RESET/EJECT switch back into the upper casing. This might be tricky on first attempt. Put the switch flat in correct orientation against the underside of the upper casing. Push it toward the holes through which the buttons emerge keeping the switch parallel with the short side of the casing. When a resistance is felt to the push, slide the buttons into the holes at whatever angle is necessary. Once the buttons are located in the holes, the switch should have moved forward slightly and be properly seated in its housing. **Take great care to ensure that the flat ribbon cable is not snagged or damaged.**
6. Now put the top back onto the PS2 (again taking care not to snag or damage the flat ribbon cable).
7. Turn the PS2 upside down and re-insert to casing screws.

USING THE MESSIAH 2

BOOTING PS2 ORIGINALS (CD or DVD, DVD9 ALL REGIONS)

- Switch on the PS2 to STANDBY (red light) and press EJECT to open the disk tray
- Insert the game into the disk tray and press EJECT or RESET to close the tray & boot the game

BOOTING PS2 BACKUPS (CD-R or DVD-R ALL REGIONS)

- Switch on the PS2 to STANDBY (red light) and press EJECT to open the disk tray
- Insert the game into the disk tray and press EJECT or RESET to close the tray & boot the game

If there is any problem booting a further DVD-R after a first DVD-R game has booted (like it requests the insertion of a Playstation 2 disk), then ensure that you do boot the game from STANDBY rather than from the EJECT button/RESET tap.

BOOTING PS1 GAMES (CD or CD-R ALL REGIONS)

- Put the PS2 into STANDBY mode (red light)
- Press and hold **EJECT** for at least 1 second to open the disk tray and set PS1/DVD mode
- Place the PS1 game into the disk tray and press **EJECT** to close the tray. The game will boot.
- You can also tap RESET and the PS2 will remain in PS1 mode and boot the game.

PLAYING LOCAL REGION DVD/DVD-R MOVIES

- Put the PS2 into STANDBY mode (red light)
- Press and hold **EJECT** for at least 1 second to open the disk tray and set PS1/DVD mode
- Place the movie into the disk tray and press **EJECT** to close the tray. The movie will play.
- You can also tap RESET and the PS2 will remain in PS1/DVD mode and play the movie.

PLAYING OUT-OF-REGION DVD MOVIES (Needs AR2/v2 or GS 2/v2 or DVD Region X)

- Put the PS2 into STANDBY mode (red light)
- Press and hold **EJECT** for at least 1 second to open the disk tray and set PS1/DVD mode
- Insert AR2/v2, GS2/v2 or DVDRX into the disk tray and close the tray. It will boot.
- At the menu, select DVD MOVIE PLAYER and press X on the controller
- The disk tray will eject; remove AR2/GS2/DVDRX and put the out-of-region movie into the tray
- Press EJECT or tap RESET to close the tray and wait for a few seconds
- If the Browser appears, select the gold disk and press X to complete the boot

DISABLING THE MESSIAH 2 (e.g. PS1 anti-mod protected game)

- Put the PS2 into STANDBY mode (red light)
- Press and hold **EJECT** for at least 5 seconds to open the disk tray and set 'sleep' mode
- Place the game into the disk tray and press **EJECT** to close the tray.
- You can also tap RESET; the PS2 remains disabled and boots the in-region original game.
- Using this procedure means that the game must be the same as the PS2 region
- The Messiah 2 is disabled until it has been put back to STANDBY and booted normally

TROUBLESHOOTING (no guarantees)

Tools needed

To diagnose a mis-install, you will need an 8x magnifying glass to identify bridged pins or small solder splays. A multi-meter helps also to check continuity between pin and pad on the Messiah 2. Sometimes the lacquer hasn't been adequately removed (esp. SCEX) so a continuity check helps.

PS1 backups won't boot

Suspect **SCEX** in the first instance. Remember that the PS2 components are lacquered and a good electrical connexion is necessary. It is also important to note that if too much heat is applied during soldering to the point where **SCEX** is located might have damaged that component. Otherwise suspect that you haven't put the Messiah 2 into PS1 mode.

PS2 backups/imports won't boot or Red Screen Displays

In this scenario, the disk has been seen (the groove is found and focus established) but the PS2 has been unable to identify it as a valid disk type (Audio/DVD/PS1/PS2).

Messiah 2 v1.31 has the characteristic whereby when booting a further DVD-R after a first DVD-R game has booted, the screen displays a request for the insertion of a Playstation 2 disk. In this case ensure that you boot the game from STANDBY rather than from the EJECT button/RESET tap.

In all other cases follow the hints below.

Check all soldering for bridges or balls lying beneath or behind the BIOS legs. Difficult to spot.

Check also that no wires are trapped and shorted by the metal frame. This is a common problem.

If it's all backups that won't boot, then try cleaning the laser lens with a cleaning CD. If it's just DVD-Rs that won't boot, suspect wire **E**, wires **R** or **W** or the DVD laser diode (which may need recalibration). Laser Azimuth might also need adjusting.

Then suspect solder bridges. If you can't see bridges, then it's the hard way. If the BIOS wires are attached, detach them from the BIOS and clean up. Then boot a backup using AR2/GS2. If it works, **A-I** are OK and the BIOS was the problem. (You can try this with the BIOS wires still attached but if it doesn't work, you'll have to take the BIOS wires off).

When you can boot backups (including DVD-R) with AR2/GS2, then carefully re-attach the BIOS wires, **MNOP QRTUVW**. Then try direct booting of backups and/or imports.

'Disc Reading' on Browser Screen or clicking sounds

The disk is seen (groove is found & focus established); the PS2 has identified it as a valid disk type (Audio/DVD/PS1/PS2) but cannot do anything more with the disk or takes ages to load. This is most likely a laser related issue (clean the lens and/or the disk). Or adjust the laser.

If the drive seems to load sluggishly (like it seems not to have enough power), the Messiah 2 might be grounding on the metal cage when it is closed. Use thinner double sided tape!

Screen remains black

Assuming that the electrons were whirling initially, then this is usually a mis-install on the BIOS.

If the electrons never happened, then some ribbon cables may have snagged when you put the PS2 back together. Or the pressure on wires that have been laid "in space" has caused the soldered ends to touch; the solution in this case is to lay the wires flat and hot glue them to fix.

Possibly a fuse has blown (one of those little square chips with a number on them).

If you have a memory card inserted, try removing it. Some people have had black screen issues when their memory card was inserted (see below).

DVD Movies are choppy

Suspect the media or laser condition. No Messiah 2 condition is likely to arise in this regard.

DVD Movies don't boot

Check your boot method. If booting an import movie with GS2/AR2, remember to boot GS2/AR2 with the PS1 method above (or with Messiah 2 switched off) so as to bypass what the Messiah 2 would otherwise do for PS2 games.

CD/CD-R games boot but not DVD/DVD-R

It is likely that one of the following causes applies:

- The **W** wire or the **R** may be incorrectly connected.
- The laser lens is dirty and should be cleaned with a cleaning disk or a cotton swab. A lens can easily collect dirt if the PS2 is played horizontally. The DVD is read at a higher frequency than a CD and results are more sensitive to a dirty lens.
- The laser needs re-calibrating because of wear and tear. This is a complex process and should be carried out by a competent engineer. Pot resistance should not be lowered by more than 10% otherwise there is risk of the DVD laser diode overheating and giving out.
- The laser needs replacement because of severe wear and tear. This is more likely on older PS2s especially if they have been used extensively to play DVDs or have been regularly used with a NEO2.2 mod chip and the DVD-R boot method.

The PS2 disk tray won't open when EJECT is pressed at power on

If the lights are on but you can't open the tray, then the Messiah 2 installation is likely to be incorrect and most likely the connexions to the **BIOS** chip.

Messiah 2 won't boot if Memory Card is in

... but you can re-insert the memory card after booting. This might be accompanied by a loss of controller vibration. Please examine fuse at **PS7** marked with the legend **S7**.

Colour is wrong or the screen rolls

This is the **Colour Fix** problem and is associated with what your TV can handle.

SYNOPSIS

Since PAL and NTSC are not that different in the way they encode colour signals, it's not difficult to modify the signal to achieve reasonable colour reproduction at the same time. This is achieved for PS2 with the **NTSC/PAL Colour Fix**.

You then end up with a signal having the frame rate/scan line characteristics of the original TV system, but the colour coding and sub-carrier characteristics of the local TV system. This hybrid provide a very effective way of "painting over the cracks" and allowing reasonable display of material in the other TV system.

Hybrid Standard	Sub-Carrier	Scan Rate	Lines	Usage
Pseudo PAL	4.43MHz	60Hz	525	For PAL TV
Pseudo NTSC	3.58MHz	50Hz	625	For NTSC TV

NTSC vs PAL

NTSC is characterised by 525 lines, scanned in two passes with alternate lines, at a scan rate of 60Hz (based on the electric mains) and with a colour carrier frequency of **3.58MHz**. US TVs, for example, are manufactured to understand this.

PAL] is characterised by 625 lines, scanned in two passes with alternate lines, at a scan rate of 50Hz (based on the electric mains) and with a colour carrier frequency of **4.43MHz**. European, African, Australian, NZ, Hong Kong, etc. TVs are manufactured to understand this.

THE PS2

The PS2 puts out the back whatever video signal belongs to the game that is playing. So if you have an NTSC PS2 with a no-swap chip and you play a PAL game, then the PS2 will put PAL out the back to your TV.

Most of the world uses PAL standards, The USA, Japan, Latin America, Canada and a few other South Asian countries use NTSC.

THE TV PROBLEM

Rolling Screen

In theory, modern TVs from anywhere should be able to resolve either 50Hz or 60Hz. The relevant IC is normally made with this tolerance so that manufacturing can be universal. yet, for protectionist reasons, US manufacturers generally put 60Hz only ICs into their TVs making it very difficult to view anything to do with PAL - the picture rolls because of the scan rate difference.

By contrast, TVs made in Europe (except the real budget models) are able to resolve both 50Hz and 60Hz and so rolling of the picture does not occur if it sees an NTSC TV signal.

Colour/Color

Unless the TV is *multi-system*, (most modern off-the-shelf European TVs are), your NTSC TV will not display a PAL signal in colour and your PAL TV will not display an NTSC signal in colour.

So the PS2 offers the **NTSC/PAL Colour Fix**, which is documented in various places including the Messiah 2 Install Guide.

All that this fix does is to force video signal output to the colour sub-carrier frequency of your TV.

If your TV is NTSC....

... and you want to view a PAL game in colour, there is a **colour fix point** on the PS2 (as documented in this install guide) which, if connected to **3.3v** forces the PS2 to put out **Pseudo-NTSC** (see table above). If the picture rolls, then there is little you can do to stop it as explained under **Rolling Screen** above.

If your TV is PAL....

... and you want to view an NTSC game in colour, there is a **colour fix point** on the PS2 (as documented in this install guide) which, if connected to **Ground** forces the PS2 to put out **Pseudo-PAL** (see table above). If the picture rolls, then, as with the NTSC case, there is little you can do to stop it as explained under **Rolling Screen** above.

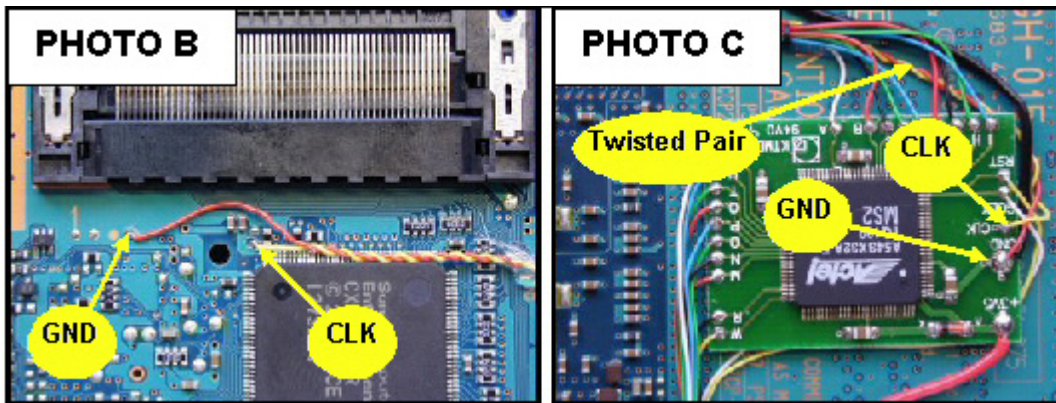

Messiah 2 appears dead)

It is very rare that a Messiah 2 is defective. However if you suspect that it might be, then check with the magnifying glass that the **M-W** and the **B-I** pins on the Actel chip are not bridged.

Sound is tinny or odd or fails

This problem has manifest itself on v5/v6 PS2s – but in theory it could happen in any case. Basically what is happening is that the wire carrying the 36MHz. clock to the Messiah 2 is inducing noise in other circuits. A long **CLK** wire at frequencies above 20MHz acts as it own capacitor which also degrades the clock. This is resolved by ensuring that there is a proper ground plane along the length of the clock wire.

The alternative ways of dealing with this in order of priority are:

1. Lay the **CLK** wire flat along the motherboard not crossing over any components.
2. Wire the **CLK** signal as a twisted pair, with the other wire being grounded at both ends (photographs **B** & **C**).
3. Use thicker wire (24 awg/25 swg) but lay it flat.

If all else fails and it still doesn't work ...

Back out of your installation, get the PS2 under control into "normal condition" and begin again. Perhaps consider obtaining professional assistance.

DISCLAIMER

The author of this document can accept no responsibility nor liability for the outcome of any work performed in conjunction with the contents of this document. Any such work carried out on a Playstation2 is at the risk of the person using this material. The material is essentially accurate and has been used to guide installation by the author of the Messiah 2 device on a v9 NTSC-J Playstation2 (SHP 50000) and a v9 PAL Playstation2 (SCPH 50003SS); however the skills of the installer are a key factor in enabling a successful outcome in the same way as the quality of media and burners used to make backups affects game loading/playing characteristics.

You are reminded that it is illegal to make pirate copies of software and it is not the intention of the author that you should make pirate copies of PS2 games.

END.